

Digital Video
DV
expo

INTRODUCING! DV EXPO LAUNCHPAD

Never before exhibited at DV Expo? Launching an innovative product?
Creating a new never-before-seen service?

November 4-6, 2008 | Los Angeles Convention Center

The DV Expo LaunchPad is the place to let your ideas loose! The digital video community is looking to see what you have on the horizon. Get featured in this high-traffic pavilion on the industry's largest show floor at a discounted package rate!

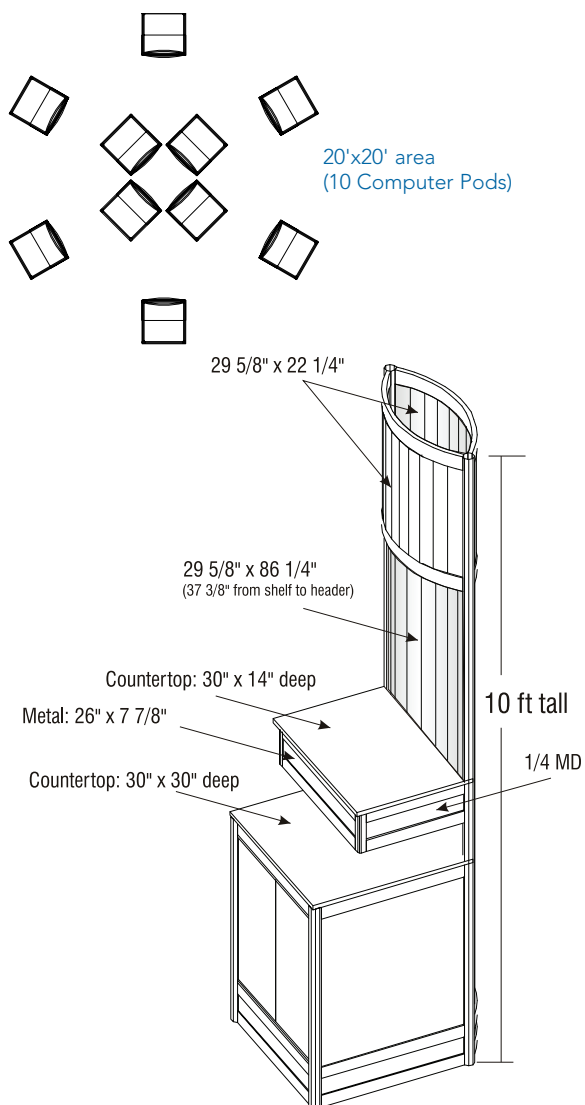

YOUR \$2800 INVESTMENT INCLUDES:

- turn-key kiosk space inside the Launchpad Pavilion
- header graphic featuring your company logo/tagline/URL
- electricity for your kiosk (to run a computer, etc.)
- Internet connection (shared T-1 drop) for your kiosk

Plus this Marketing Package (a \$2195 value):

- listing as a DV Expo exhibitor in the Show Guide, on the website and other pre-show promotional material as available
- Logo Blitz — alongside your listing on the website and in the Show Guide
- one free conference pass for a staff member
- logo included in a Show Guide ad promoting LaunchPad (created by DV Expo)

Get two days of face time with the most qualified decision-makers in the industry!

WHAT WE'LL NEED FROM YOU:

- Company logo **MUST BE SUPPLIED** as an Adobe Illustrator .EPS or .AI vector file.
- No graphics other than your company logo/tagline/URL are permitted for printing on your kiosk header.
- **Deadline: no later than October 16, 2008 for inclusion in the Show Guide and your kiosk header graphic.**
- Email logo to dmiller@nbmedia.com

RESERVE YOUR SPOT TODAY!

FOR MORE INFORMATION CONTACT: Anesha Kovalsky | Sales Manager | 212.378.0458 | akovalsky@nbmedia.com